

## NC Specifications / FANUC Series

Item		Specification	Oi-Series	Oi-TD
Controlled axis	Max. feed axes		3 AXIS	4 AXIS
	Feed axes		X/Z/(Cs)	X/Z/(Cs)
	Max. simultaneously controlled axis		3	4
	Least command increment	0.001mm / 0.0001"	○	○
Operation functions	Pulse handle feed	X1, X10, X100	○	○
	Feedrate per minute	G98	○	○
	Feedrate per revolution	G99	○	○
Interpolation functions	Linear interpolation	G01	○	○
	Circular interpolation	G02, G03	○	○
	Dwell	G04	○	○
	Polar coordinate interpolation	G12.1, G13.1	○	○
	Cylindrical interpolation	G70.1	○	○
	Variable lead thread cutting	G34	○	○
	Continuous threading		○	○
	Reference position return	G28	○	○
	Reference position return check	G27	○	○
Feed function	Rapid traverse rate override	F0, 25%, 50%, 100%	○	○
	Feedrate override		0~150%	0~150%
Spindle function	Spindle orientation		○	○
	Rigid tapping		○	○
Tool functions	Tool number command	T4-Digt / T2-Digt	T4-Digt	T4-Digt
	Tool nose radius compensation	G40 ~ G42	○	○
	Tool offset pairs		○	○
	Tool geometry/wear offset	GEOMETRY & WEAR DATA	○	○
	Tool life management		○	○
	Tool path graphic display		○	○
	Automatic tool offset	G36, G37	-	○
	Direct input of tool offset value measured B		○	○
Program input	Absolute/incremental programming		○	○
	Multiple repetitive cycle	G70 ~ G76	○	○
	Canned cycles	G90, G92, G94	○	○
	Inch/metric conversion	G20 / G21	○	○
	Program restart		○	○
	Retraction for rigid tapping		○	○
	Max. programmable dimension	±99999.999mm/±9999.9999"	○	○
	M function	M3 digit	○	○
	Custom macro		○	○
	Canned cycle for drilling		○	○
	Direct drawing dimension programming		○	○
	Programmable data input	G10	○	○
	Optional block skip		○	○
	Workpiece coordinate system	G52 ~ G59	○	○
	Number of registerable programs		400EA	400EA
Setting and display	Alarm & Operator history display	ALARM & OPERATION DISPLAY	○	○
	Run hour and parts count display	RUNNING TIME & PART NO. DISPLAY	○	○
	Display spindle & servo overload	SPINDLE & SERVO LOAD DISPLAY	○	○
	Self-diagnosis function		○	○
	Extended part program editing	COPY, MOVE, CHANGE OF NC PROGRAM	○	○
Data input/output	Display screen		8.4" color	8.4" color
	Memory card input/output		○	○
	USB memory input/output		○	○
Editing operation	Part program storage size	512Kbyte(1280m)	○	○
Manual guide i	Manual Guide i		x	○

# SMEC

# PL 1600 Series

## CNC TURNING CENTER



**SMEC**  
SMEC CO.,LTD.

**SMEC Co., Ltd.**

157-10, Goldenroot-ro, Juchon-myeon, Gimhae-si, Gyeongsangnam-do, Korea  
Tel +82 55 340 4800 Fax +82 55 340 4740  
http://www.esmec.com

**SMEC**  
Smart One,  
Global One  
www.esmec.com



**SMEC**  
SMEC CO.,LTD.

- 1988 - Started as Samsung Heavy Industries Machine Tools Business
- 1989 - Horizontal and vertical machining center technology partnership with OKK Japan
- 1991 - Turning center and vertical machining center technology partnership with Mori Seiki
- 1996 - 5-sided processing center technology partnership with Toshiba
- 1999 - Spun out from Samsung Aerospace Industries and established SMEC Co., Ltd

**SMEC**

Company

Engineering

Machine Tools

Samsung

## PL 1600 series

PL 1600/1600C/1600M/1600CM

Strongest in class with superb structural design  
Simultaneous heavy duty and precision turning

- 45 degree torque tube type bed to support heavy duty turning
- Significantly reduced non-cutting time and efficient turning
- Low-center of gravity reducing vibration, thermal deformation and improving rigidity



## High Accuracy, High Rigidity Spindle

### Pin Tube Rib Design for Minimal Axis Heat Transfer

Radiator fan-like pin tube rib design dissipates heat, maintaining minimal thermal expansion.

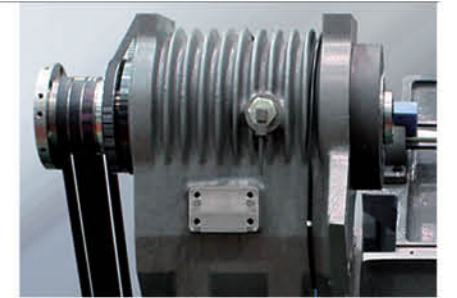

3 sets of precision angular contact ball bearings are located in the front of the spindle, and a double row of cylindrical roller bearing is located in the rear to ensure high speed cutting capabilities with precision.

### SPINDLE & HEADSTOCK

The Spindle and Headstock are machined and ground in a temperature controlled environment and assembled in a clean room.

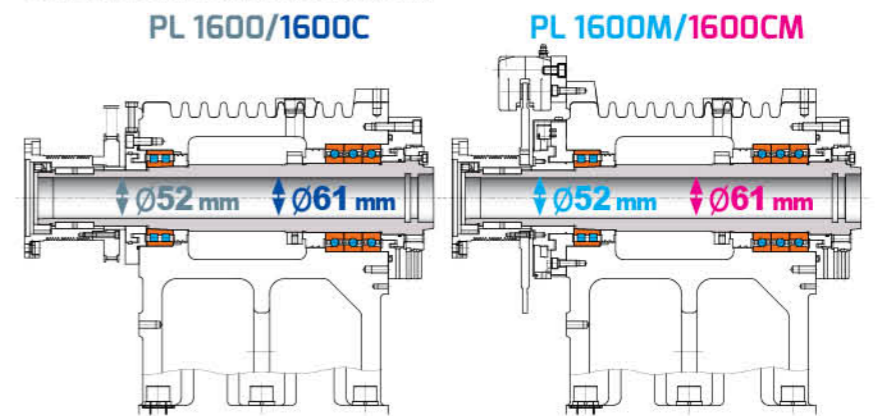

Spindle Power & Torque Diagram

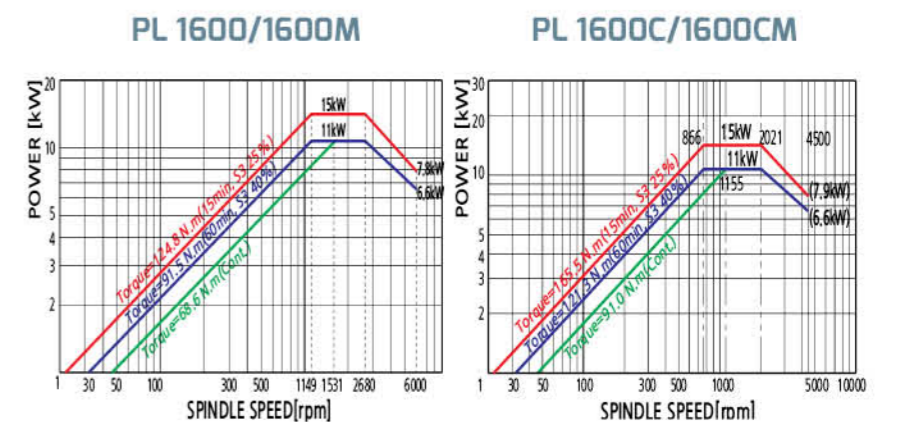

PL 1600/1600C/1600M/1600CM a compact, ultra precision Turning Center, combined with SMEC's advanced technological features.

**Highly Reliable and Rigid Structural Design**

- One piece Meehanite casting with heavily ribbed torque tube design
- Rigid bed supports for powerful cutting
- Excellent vibration dampening and thermal displacement design

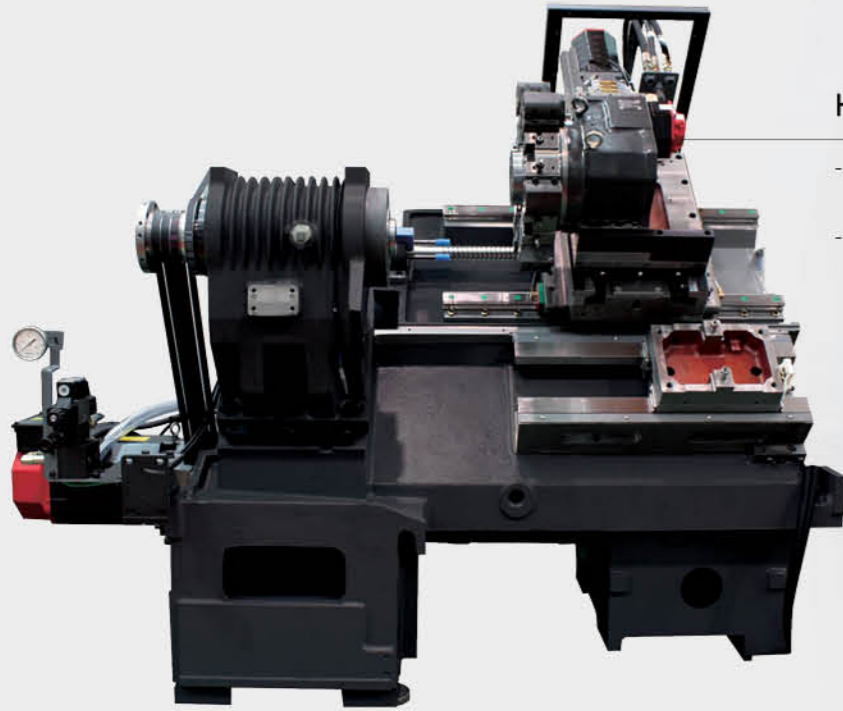

Description	PL 1600	PL 1600M	PL 1600C	PL 1600CM
Max. machining length	mm 307	291	270.5	261.6
X/Z axis travel	mm	165/350		
X/Z rapid traverse rate	m/min	24/30		
Chuck size	inch	6		8
Spindle Speed	rpm	6,000		4,500
Motor (cont./30min)	kW	11/15		11/15



PL 1600 (High Speed Servo Turret)

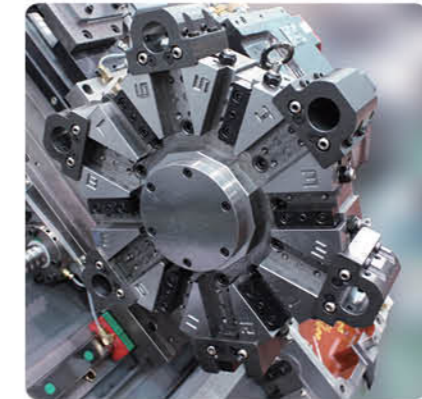

Indexing Time  
**1.3sec at 60Hz**

Number of tool positions  
**12stations**

PL 1600C (High Speed Servo Turret)



Indexing Time  
**0.2sec at 60Hz**

Number of tool positions  
**10stations**

**High Speed, Heavy Duty Hyd. Index Turret**

TDriven by a high torque hydraulic index motor, the 10 or 12-station heavy-duty turret can accept tools on both left and right side of each station. Turret indexing (repeatability ± 0.005)is non-stop, bi-directional with a fast 0.2 second next station index time. A large diameter (Ø130) Curvic coupling with 3,300kgf damping force enables precision as well as heavy-duty cutting.

PL 1600 (High Speed Servo Turret)

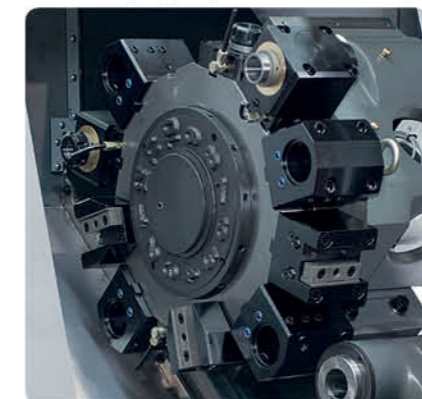

**Milling Motor Torque Diagram**

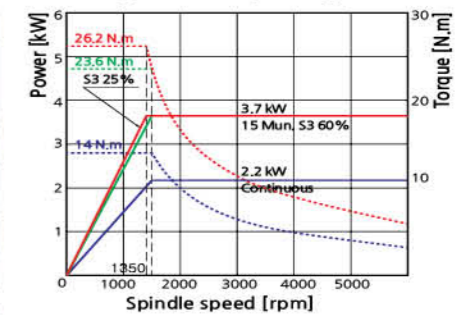

Indexing Time  
**0.15sec at 60Hz**

Number of tool positions  
**12stations**

**BMT Milling Turret (M Type)**

PL 1600M/1600CM are equipped with standard 12-station BMT turret capable of accepting rotary tools at any station, providing flexible machining thru various machining operations in just one set-up. Each BMT holder is securely tightened by 4 screws, allowing the turret to perform heavy-duty cutting, milling and drilling operations. Turret indexing is non-stop, bi-directional with a fast 0.15 second next station index time.

### Rigid 45 degree Slant Bed

45 degree slant torque tube design bed and wide guide slide way ensure long term rigidity and machining accuracy.

Featuring superior workability and chip-discharging capability, the bed is designed in a single tube structure boasting strong durability even in heavy-duty cutting.

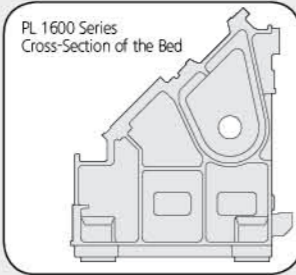

### Highly reliable Lubrication unit

Highly reliable LUBE unit discharges the right amount of lubrication oil to each guide way automatically.

### Hexahedral Slide Way Frame (X-axis)

Wide integral way is machined from casting, induction hardened and precision ground to ensure long-term rigidity, machining accuracy and heavy-duty machining.

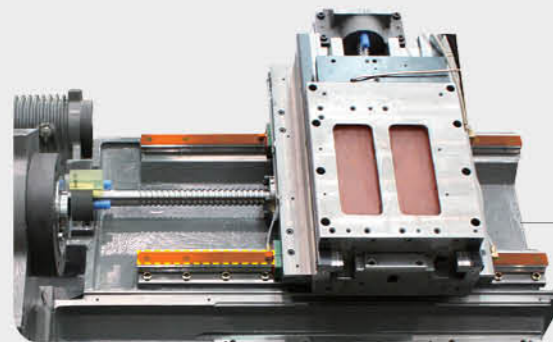
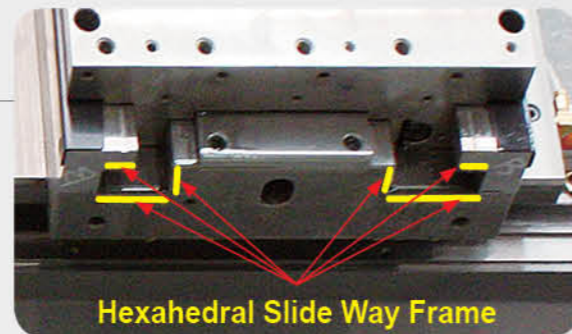

### Linear Slide Way Frame (Z-axis)

Sustained by high-rigidity Linear Guide to realize high-speed and precision machining.

### Pre-tensioned and Double Anchored Ballscrews

All axes ballscrews are pre-tensioned, heat treated, and fixed by double anchors on both ends, providing ultimate rigidity and minimal thermal growth.

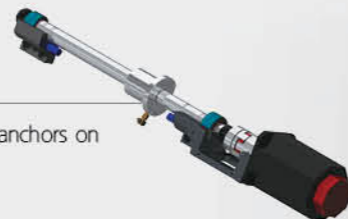

### Compact design for easy automation

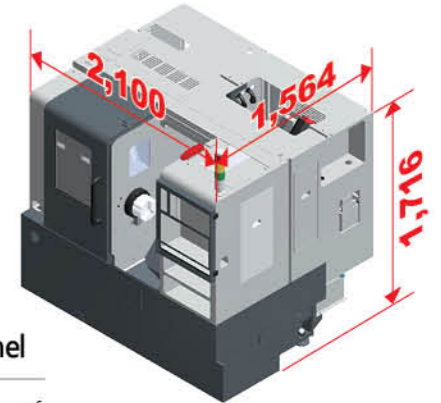

### User friendly centralized control panel

1. Solid BEZEL for maintaining the original form of control panel
2. High-reliability of Fuji products(Cycle Start, Feed Hold, Power On/Off, key S/W)
3. Preventing to erase the name of the buttons with transparent cap (cap changable)
4. High-intensity LED lamp
5. Manual turret control and tool No display
6. Serve control panel for additional options
7. Swivel control panel for user friendly



### Electric Cabinet Made with Highly Reliable Components

- Magnet switch, Circuit breaker, Key S/W(FUJI)
- Relay(WEIDMULLER사, OMRON)



### Easy chip disposal

45 degree slant bed to achieve easy chip disposal and tool inspection as well as tool change

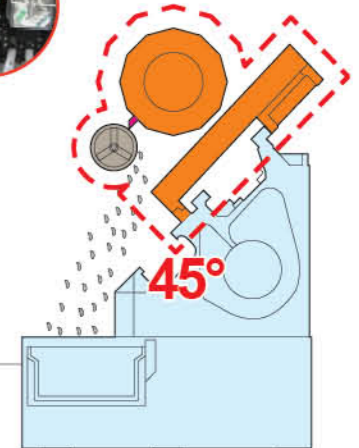

High Precision

Surface Roughness



Model : PL 1600(Material : SM 45C, O.D Cutting)

Roughness

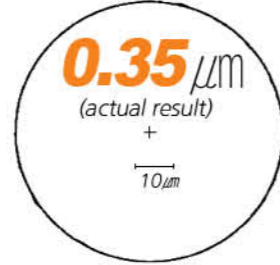

Cutting condition	
Tool	Diamond tool <nose radius 0.020 inch>
Material	AL150<Aluminum>
Cutting speed	230 m/min
Feedrate	0.05 mm/rev
Depth of cut	0.1 mm
Outer diameter	200 mm
Filter	1-50

Processing Speed

Turning Performance (material:SM45C) PL 1600

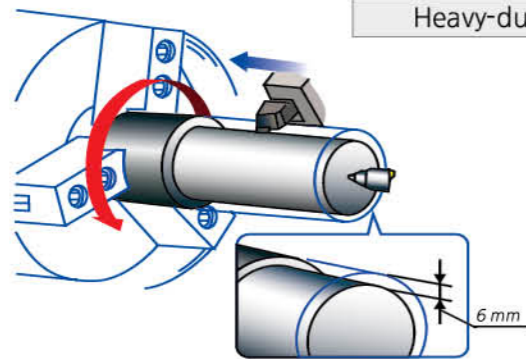

Heavy-duty cutting (O.D) <20mm×20mm qualified tool>

Spindle speed  
**868 rpm**  
Cutting speed  
**120 m/min (383 fpm)**  
Depth of cut  
**6 mm <Spindle Load 50%>**  
Feedrate  
**0.3 mm/rev (0.08 ipr)**

Optional Accessories

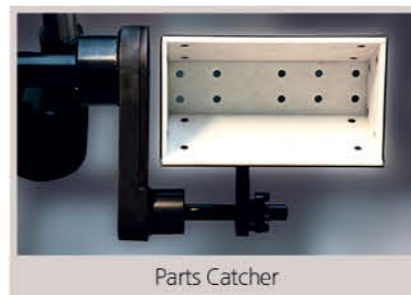
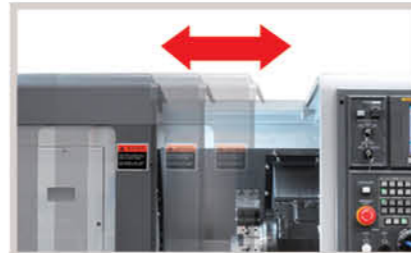

Tooling System

Unit : mm

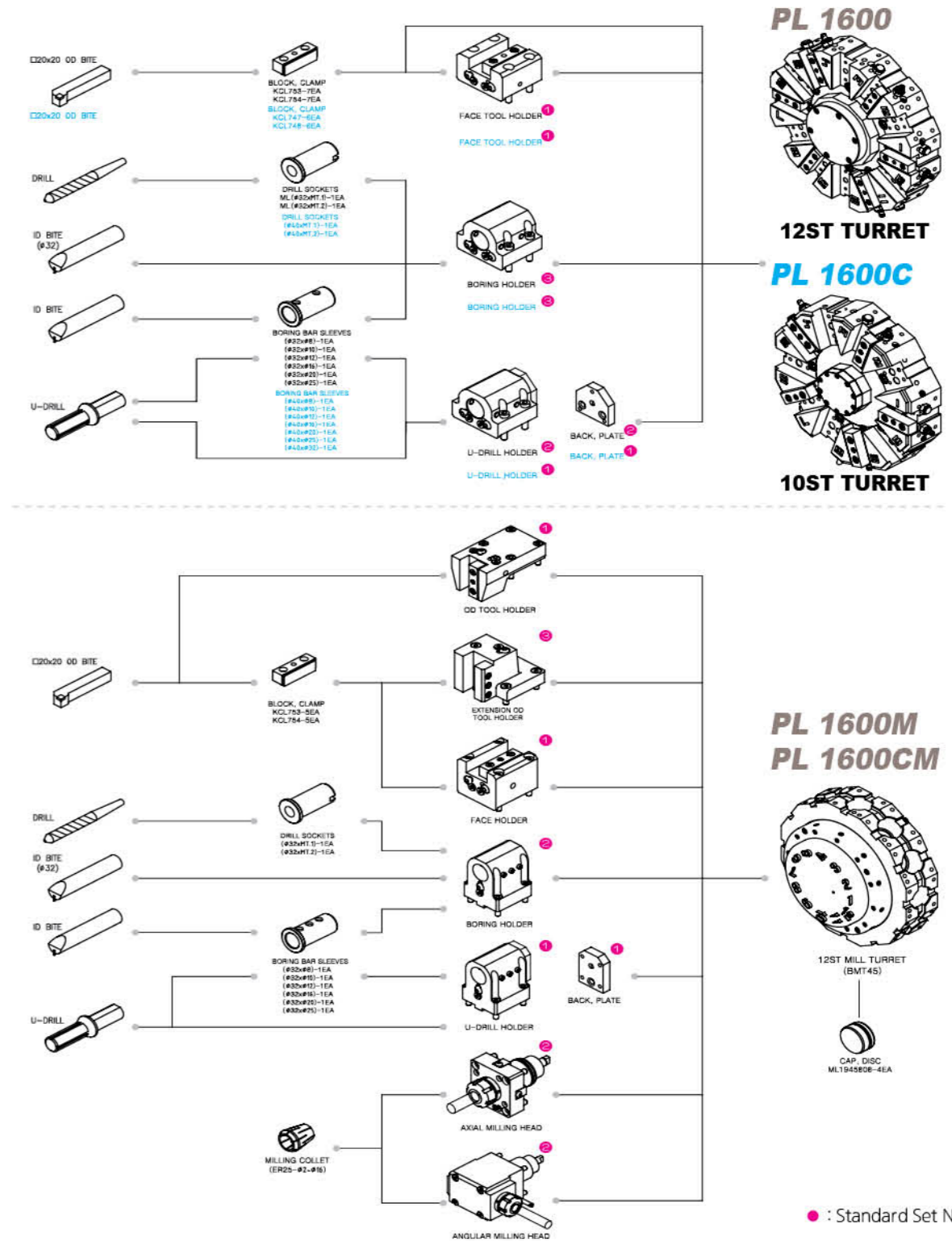

Machine Dimensions

Unit : mm

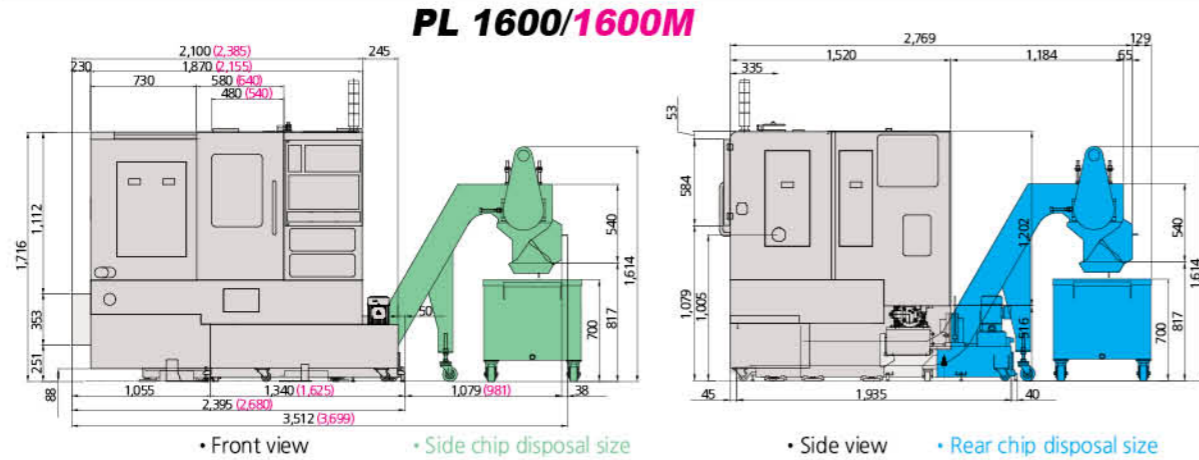

Turret Head Interference

Unit : mm

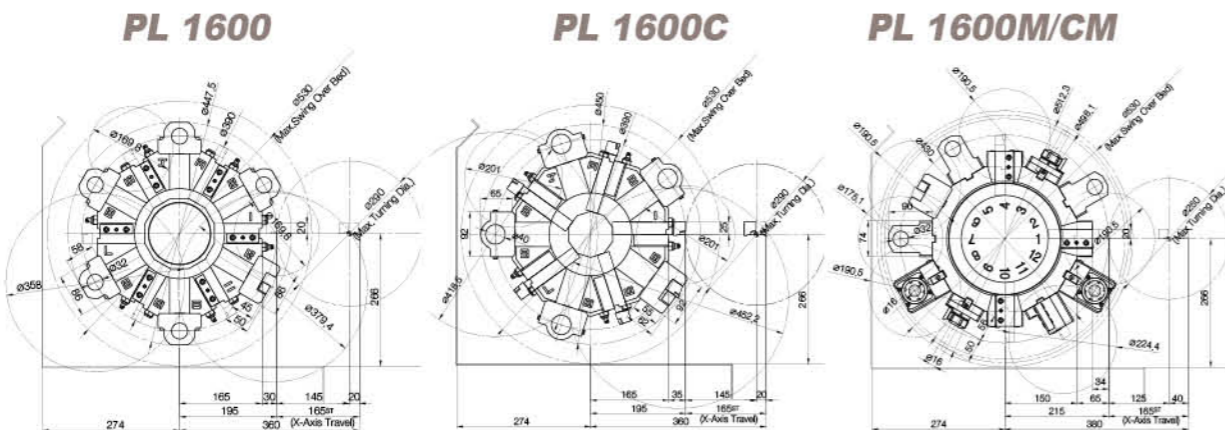

Work Range

Unit : mm

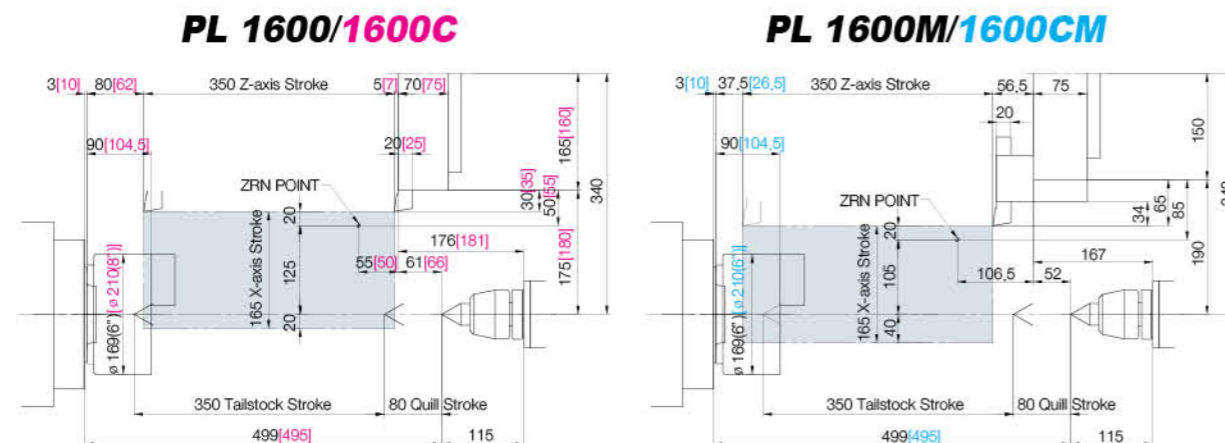

Major Specifications

DESCRIPTION		PL 1600	PL 1600M	PL 1600C	PL 1600CM
Capacity	Swing over the bed	mm	530	530	530
	Swing over the cross slide	mm	290	290	290
	Max. machining diameter	mm	290	250	290
	Max. machining length	mm	307	291	270.5
Main Spindle	Chuck size	inch	6	6	8
	Spindle Speed	rpm	6,000	6,000	4,500
	Spindle nose	ASA	A2-5	A2-5	A2-6
	Bore diameter	mm	61	61	61
	Draw tube I.D.	mm	52	52	52
	Motor(cont./30min)	kW	11/15	11/15	11/15
Travel	X/Z axis travel	mm	165/350	165/350	165/350
	X/Z rapid traverse rate	m/min	24/30	24/30	24/30
	X/Z feed motor	kW	1.8/1.8	1.8/1.8	1.8/1.8
Turret	Number of tool positions	st.	12	12[BMT45]	10
	Indexing time	sec	0.2	0.15	0.2
	Shank size for square tool	mm	20	20	25
	Shank diameter for boring bar	mm	32	32	40
Tailstock (Option)	Tailstock travel	mm	350	350	350
	Tailstock quill travel	mm	80	80	80
	Tailstock spindle taper	MT	MT4	MT4	MT4
	Tailstock quill diameter	mm	65	65	65
ELECTRIC POWER SUPPLY	kVA/V	22 / 220	22 / 220	22 / 220	22 / 220
REQUIRED FLOOR SPACE (L×W)	mm	2,295×1,760	2,580×1,760	2,395×1,760	2,680×1,760
MACHINE WEIGHT	kg	2,850	3,100	2,940	3,190
CONTROLLER		Fanuc Series			

\*Figures in inches are converted from metric measurements.

Standard Accessories

- Coolant Unit (4.5 bar at 60Hz)
- Work Light
- Splash guard & Side Coolant Tank
- Tool/Work box
- 6" Hyd. Hollow Chuck (PL1600/PL1600M)
- 8" Hyd. Hollow Chuck (PL1600C/PL1600CM)
- Soft Jaw 3 sets
- Hard Jaw 1 set
- Leveling Unit
- Main Spindle Orientation
- Chuck Clamp Foot Switch
- Chuck Clamp Confirmation
- Chuck Pressure Switch
- Manuals/Parts List
- Safety Precaution on Name Plate
- Door Interlock
- \* Door Interlock, Chuck Clamp Confirmation are CE, KCS standard.

Optional Accessories

- Side Chip Conveyor
- Rear Chip Conveyor
- Coolant Tank
- Chip Bucket
- Chuck Clamp Confirmation
- Dual Pressure Chucking
- Auto-Door & Safety Edge
- Coolant Gun
- Coolant Chiller
- Coolant Pressure Switch
- Coolant Level Switch
- High Pressure Coolant (4.5 bar, 7bar, 10bar, 14.5bar, 20bar-60hz)
- Signal Tower (Yellow, Red, Green, Buzzer)
- Mist collector
- Bar Feeder Interface
- Air Gun
- Parts Catcher
- Shower Coolant
- Transformer
- Work Counter
- Air Blower
- Chuck Coolant
- CE spec.